



FITTING INSTRUCTIONS

Part Number: **3540021**

Product **JACK MOUNTING BRACKET**

Description:

Suited to **SUITS FORD RANGER MY22, VW AMAROK MY22**
vehicle/s:

WARNING

ALSO, NOTE THE FOLLOWING:

- ◆ This product must be installed exactly as per these instructions using only the hardware supplied.
- ◆ In the event of damage to any mount component, contact your nearest authorised ARB stockist.
- ◆ Do not use this product for any vehicle make or model, other than those specified by ARB.
- ◆ This product or its fixing must not be modified in any way.
- ◆ The installation of this product may require the use of specialized tools and/or techniques.
- ◆ It is recommended that this product is only installed by trained personnel.
- ◆ These instructions are correct as at the publication date. ARB Corporation Ltd. cannot be held responsible for the impact of any changes subsequently made by the vehicle manufacturer.
- ◆ During installation, it is the duty of the installer to check correct operation/clearances of all components.
- ◆ Work safely at all times.
- ◆ Unless otherwise instructed, tighten fasteners to specified torque.

ARB 4x4 ACCESSORIES

Corporate Head Office

42-44 Garden St
Kilsyth, Victoria
AUSTRALIA 3137

Tel: +61 (3) 9761 6622
Fax: +61 (3) 9761 6807

Australian enquiries
North & South American enquiries
Other international enquiries

sales@arb.com.au
sales@arbusa.com
exports@arb.com.au

www.arb.com.au

GENERAL CARE AND MAINTENANCE

By choosing an ARB Accessory, you have bought a product that is one of the most sought after 4WD products in the world. Your Accessory is properly engineered, it's reliable and is a quality accessory that represents excellent value. To keep your Accessory in original condition it is important to care and maintain it following these recommendations:



- As part of any Pre Trip Preparation, or on an annual basis, it is recommended that a thorough visual inspection of the vehicle's accessories is carried out, making sure that all bolts and other components are torqued to the correct specification. Also check that all wiring sheaths, connectors, and fittings are free of damage. Replace any components as necessary. This service can be performed by your local authorized ARB Stockist.

FITTING REQUIREMENTS

REQUIRED TOOLS FOR FITMENT OF PRODUCT:

BASIC TOOL KIT	TORX KEYS
SCREWDRIVER SET	Loctite 243

HAVE AVAILABLE THESE SAFETY ITEMS WHEN FITTING PRODUCT:

Protective eyewear 	Hearing protection 
--	--

NOTE: 'WARNING' notes in the fitting procedure relate to OHS situations, where to avoid a potentially hazardous situation it is suggested that protective safety gear be worn or a safe work procedure be employed. If these notes and warnings are not heeded, injury may result.

FASTENER TORQUE SETTINGS:

SIZE	Torque Nm	Torque lbft
M8	22Nm	16lbft

PARTS LISTING

APPLICATION.	PART NO.	QTY	DESCRIPTION
FIT JACK MOUNT	5670092	1	PRE ASSEMBLED JACK MNT
FIT FORWARD MNT	4655293	1	FORWARD JACK MNT
BOLT KIT	4584296	6	WASHER FLAT M10x30x5 TZP480
	4584393	14	WASHER FLAT M8x19x2 HV300 BTZP480
	6151212	5	NUT HEX NYLOC M8x1.25 ZNB480
	6151625	9	SCREW BHD M8x25 TX PC8.8 ZNB480 NYLON PATCH

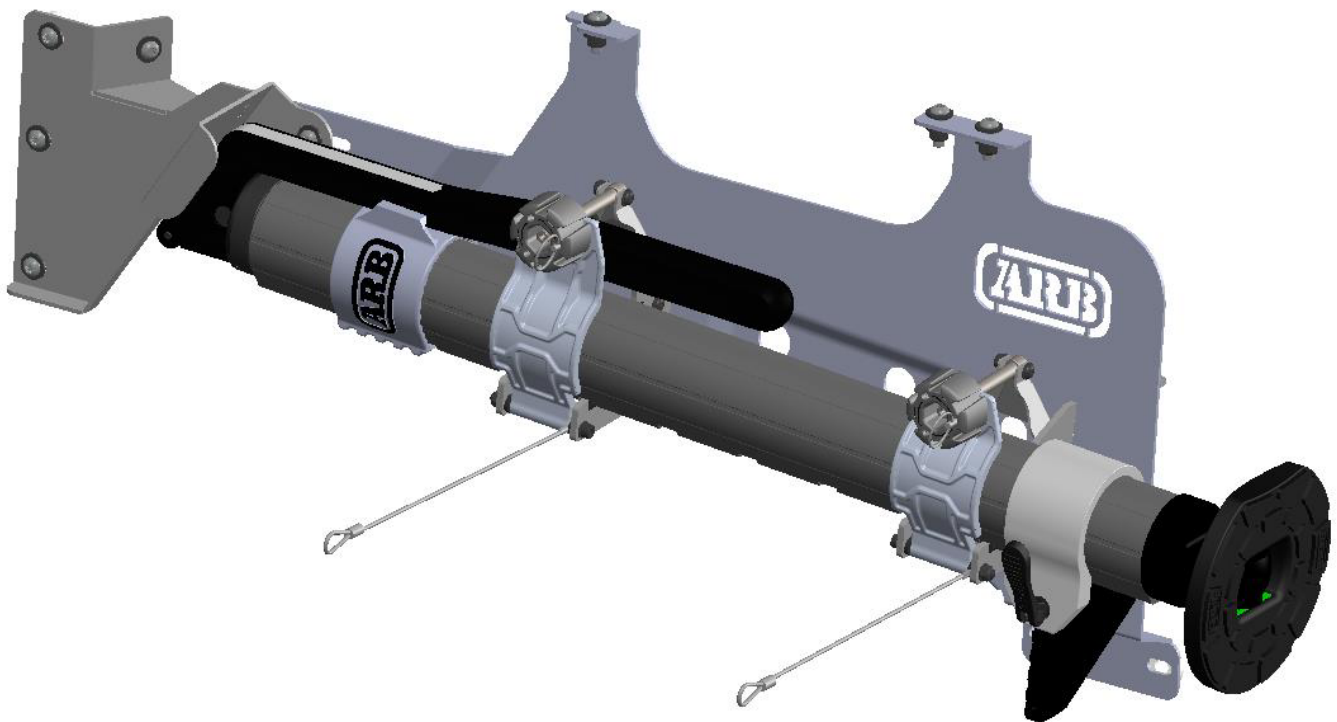

FITTING PROCEDURE

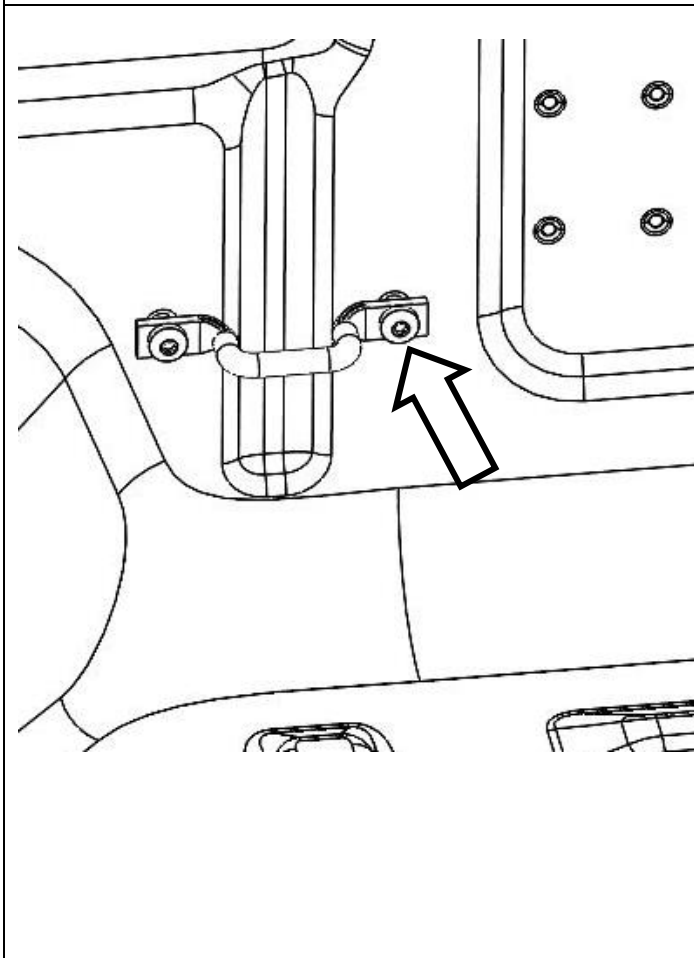

1. Using a T40 TORX Key, remove the two tie down points from RHS of the tub.

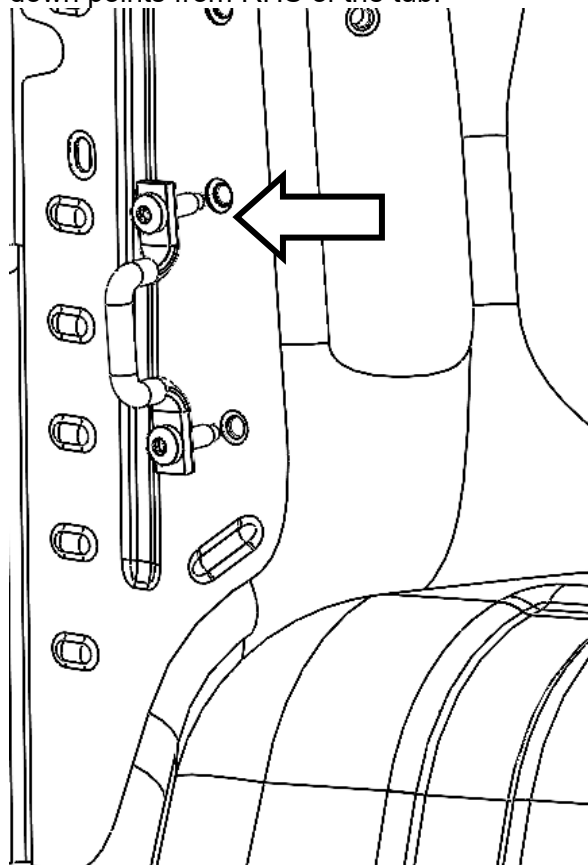

2. Remove the four threaded scrivenets from the RHS tub trim.

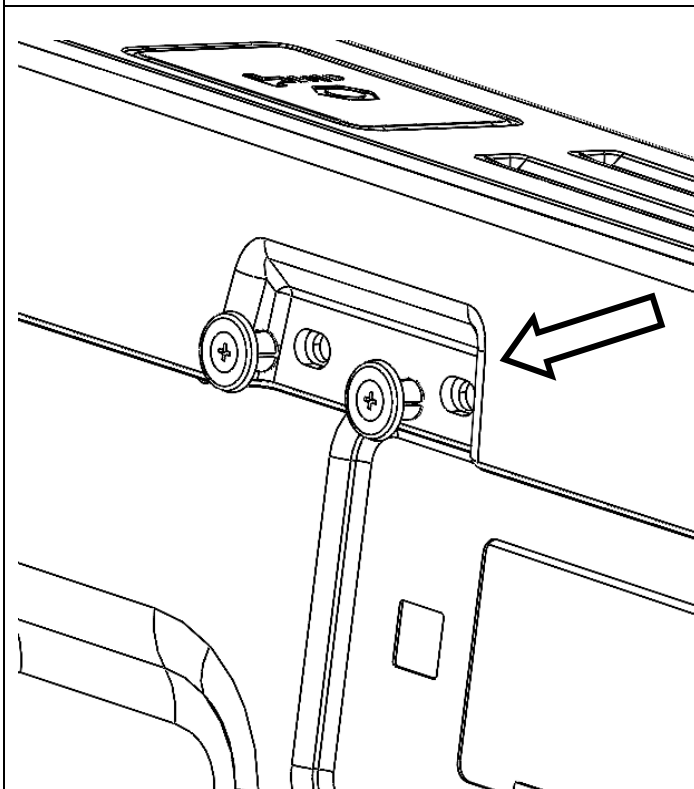

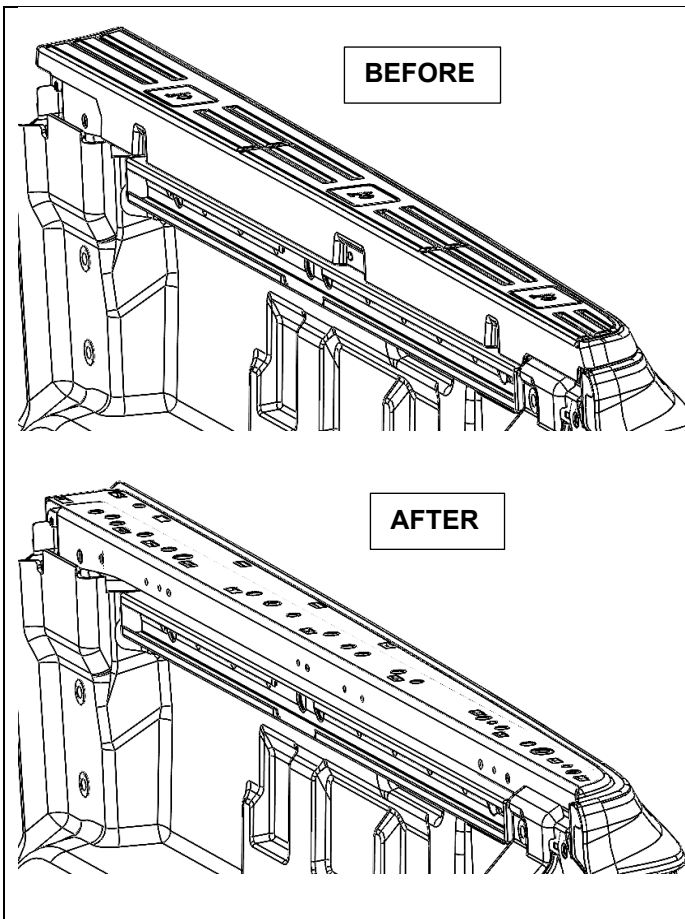

3. To remove the RHS tub trim, start at the rear corner. Using a long, flat blade screwdriver, push both sides to release.

The inner location tabs can be accessed from inside the tub and squeezed to release.

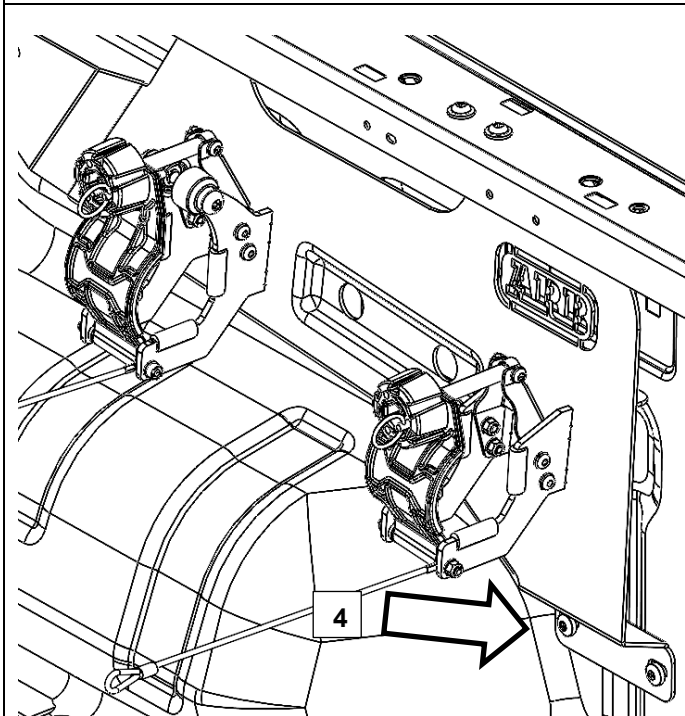
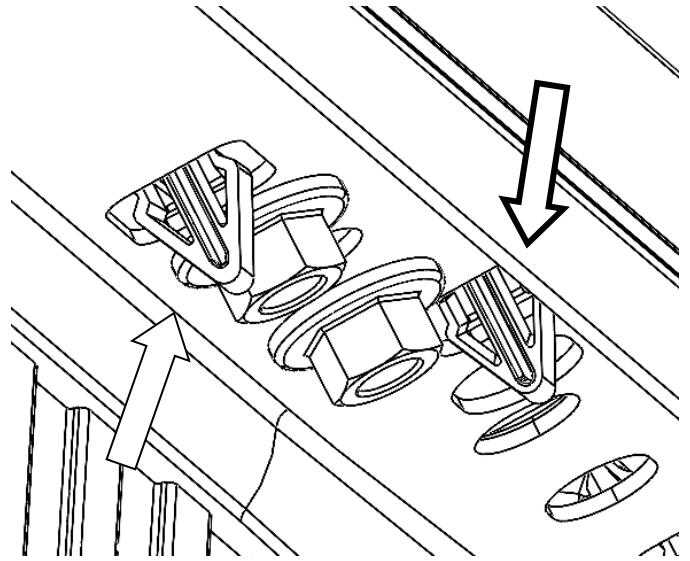

4. Lift the Jack mount assembly into place and loosely fit two OEM tie down fasteners to hold the Jack mount assembly in place.

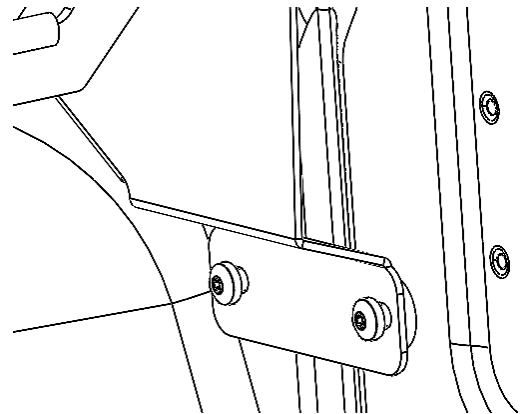

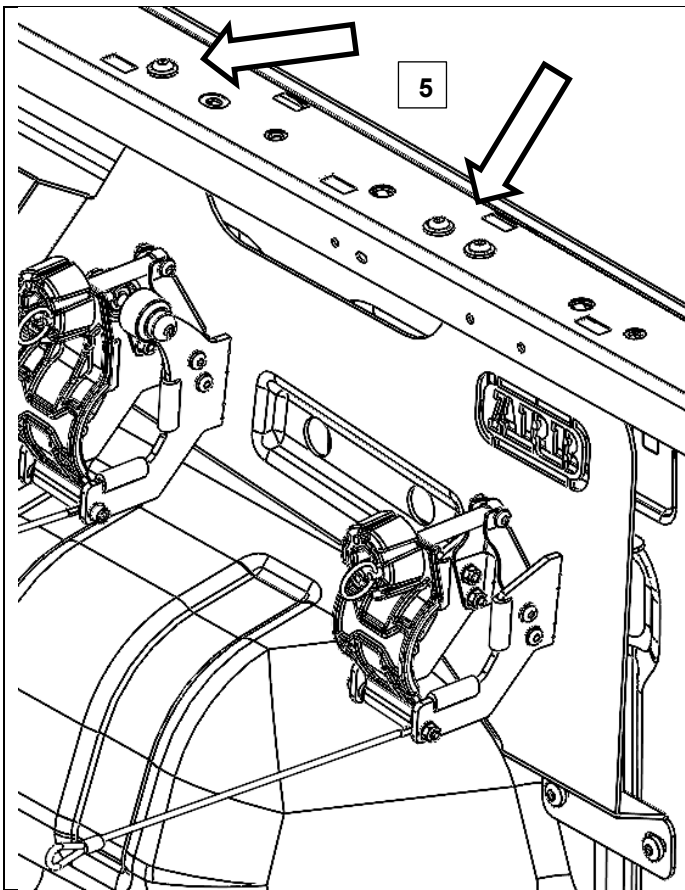

5. Three M8 buttonhead screws, six M8 washers and three M8 Nyloc nuts are used along the top to fit the Jack mount assembly.

Leave loose at this stage.

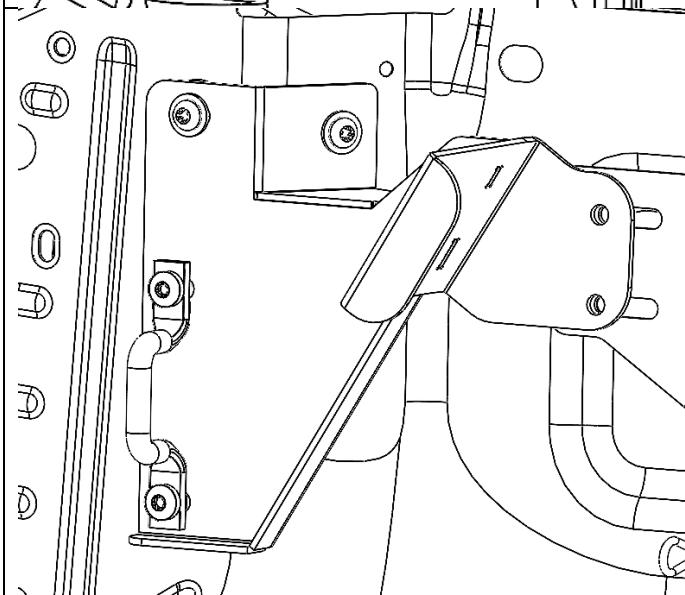

6. The forward Jack mount is attached with two M8 buttonhead screws, two M8 washers and four **LARGE** washers. Reuse the OEM tie down point and two OEM fasteners.

The **LARGE** washers are used as spacers between the Mount and the tub body.

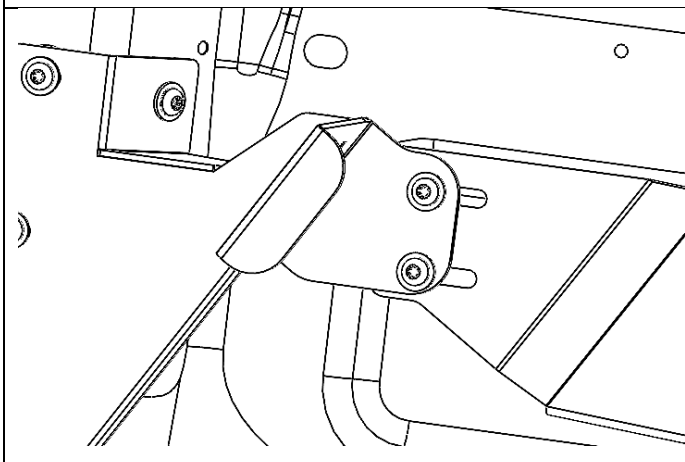
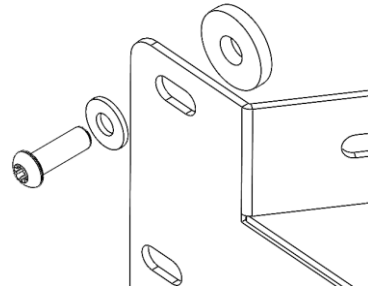

7. Use two M8 buttonhead screws, four M8 washers and two M8 nyloc nuts to fasten the forward jack mount to the Jack mount assembly.

Leave loose at this stage.

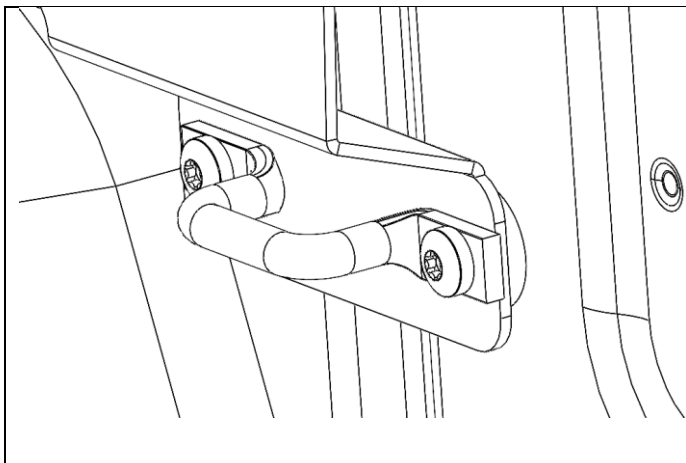

8. Remove the two OEM fasteners fitted in step 4, place two LARGE washers between the tub body and the mount.
9. Refit the OE tie down point, centre the mount to the tie down point and torque the fasteners to specification.

 M8 – 22Nm – 16lbft

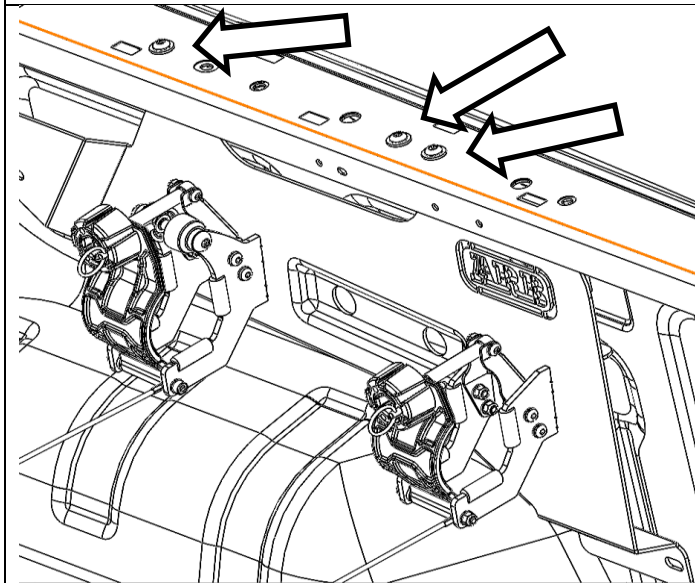

10. Tighten the top three fasteners to spec.

 M8 – 22Nm – 16lbft

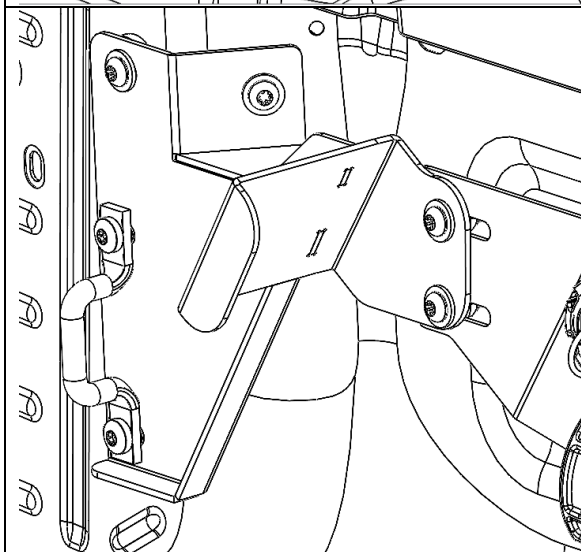

11. Tighten the four fasteners for the front mount first, then tighten the two between the front mount and the Jack mount assembly.

 M8 – 22Nm – 16lbft

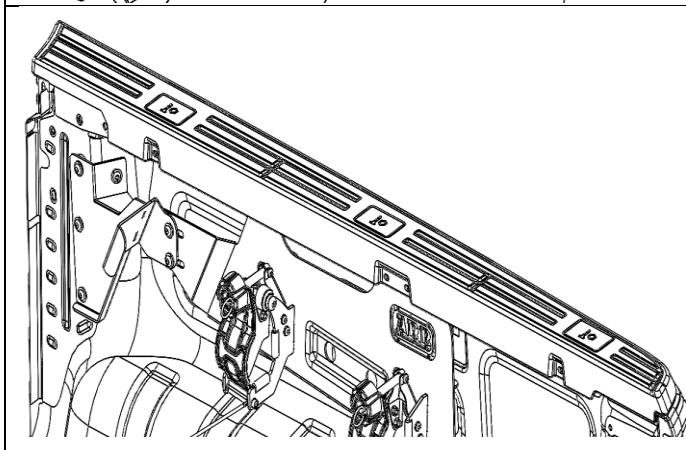

12. Carefully refit the top tub trim starting at the front making sure the locating pins are lined up, then refit the four screws removed in Step 2.

USER INFORMATION

To load the ARB Jack onto the mount, rotate the 2 knobs to a vertical position and rotate both clamps downwards.

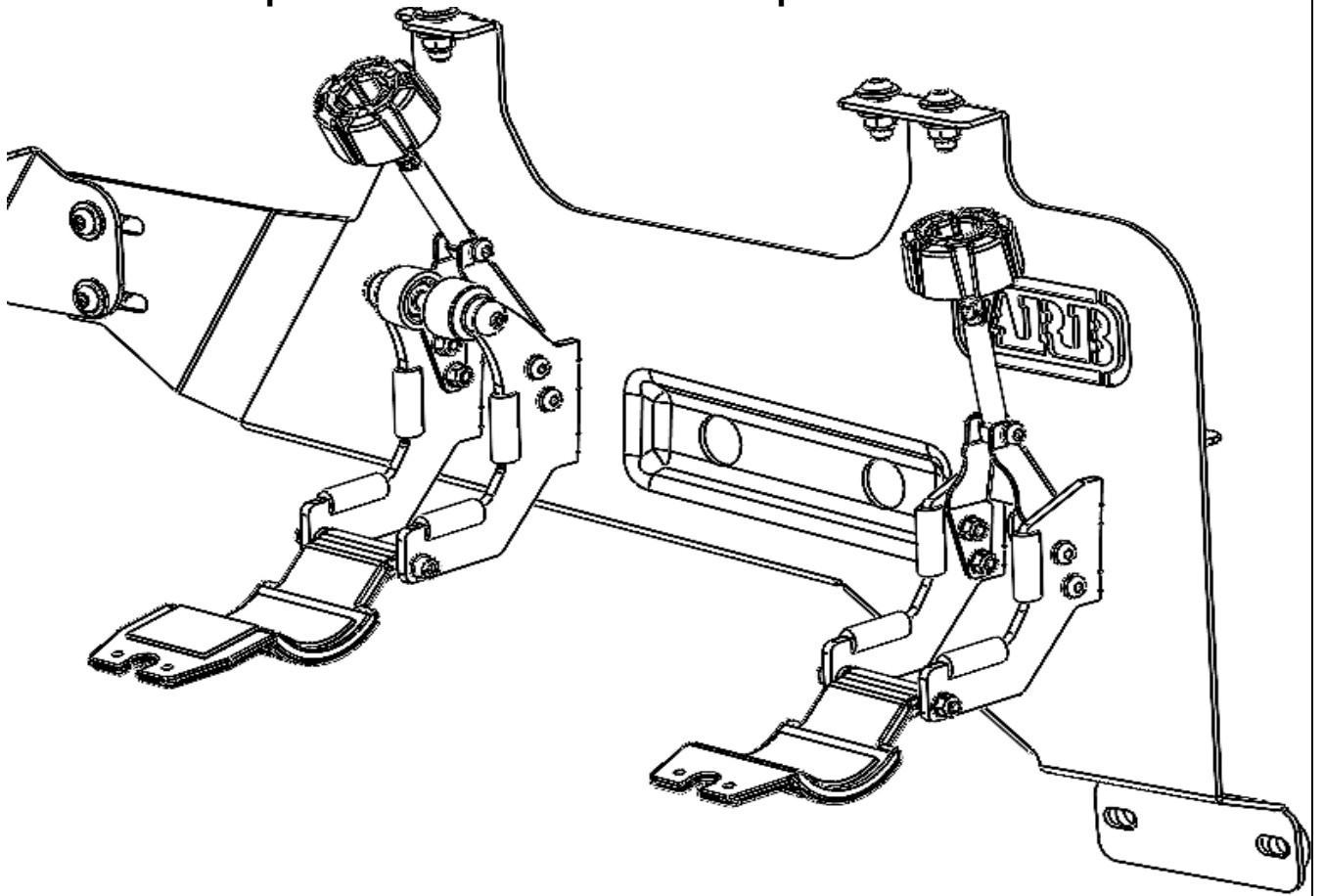

Sit the Jack onto the mount.
Locate the 2nd and 3rd slots onto the mount.

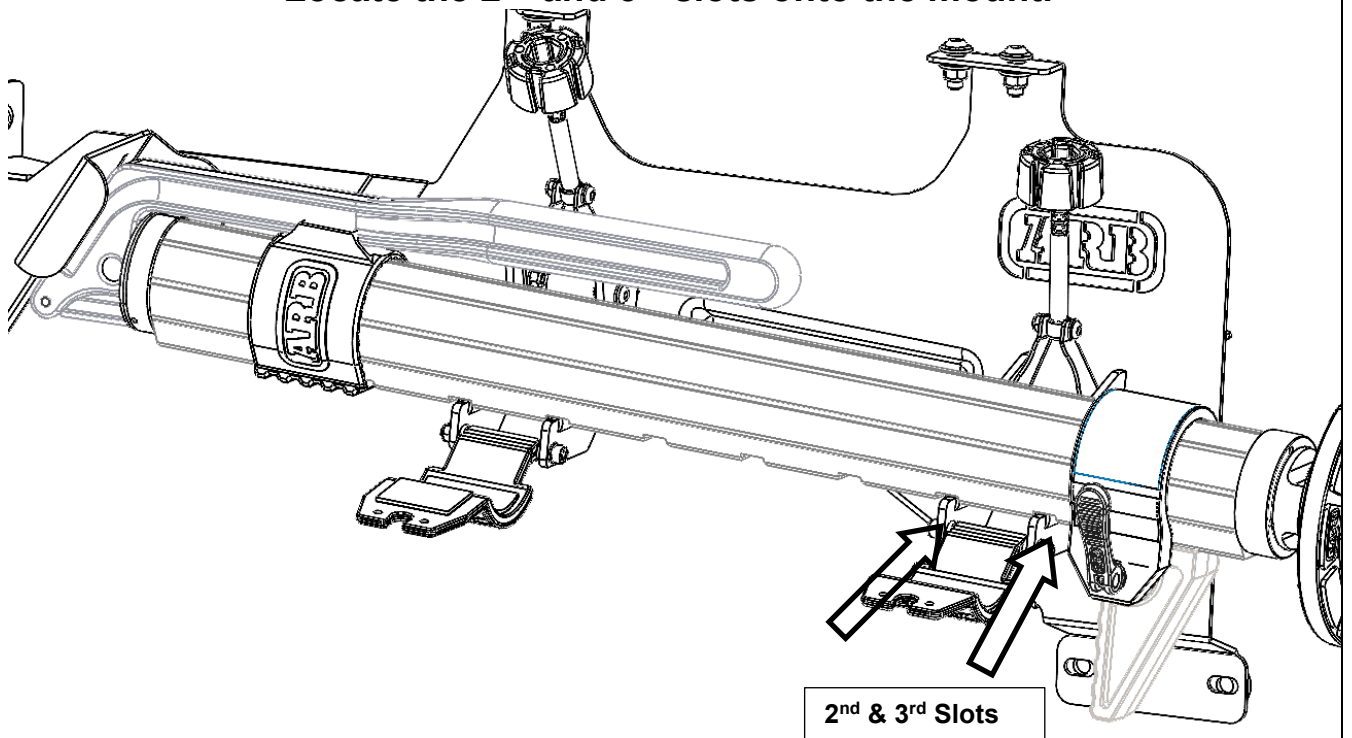

Rotate the 2 clamps up to contact the Jack.

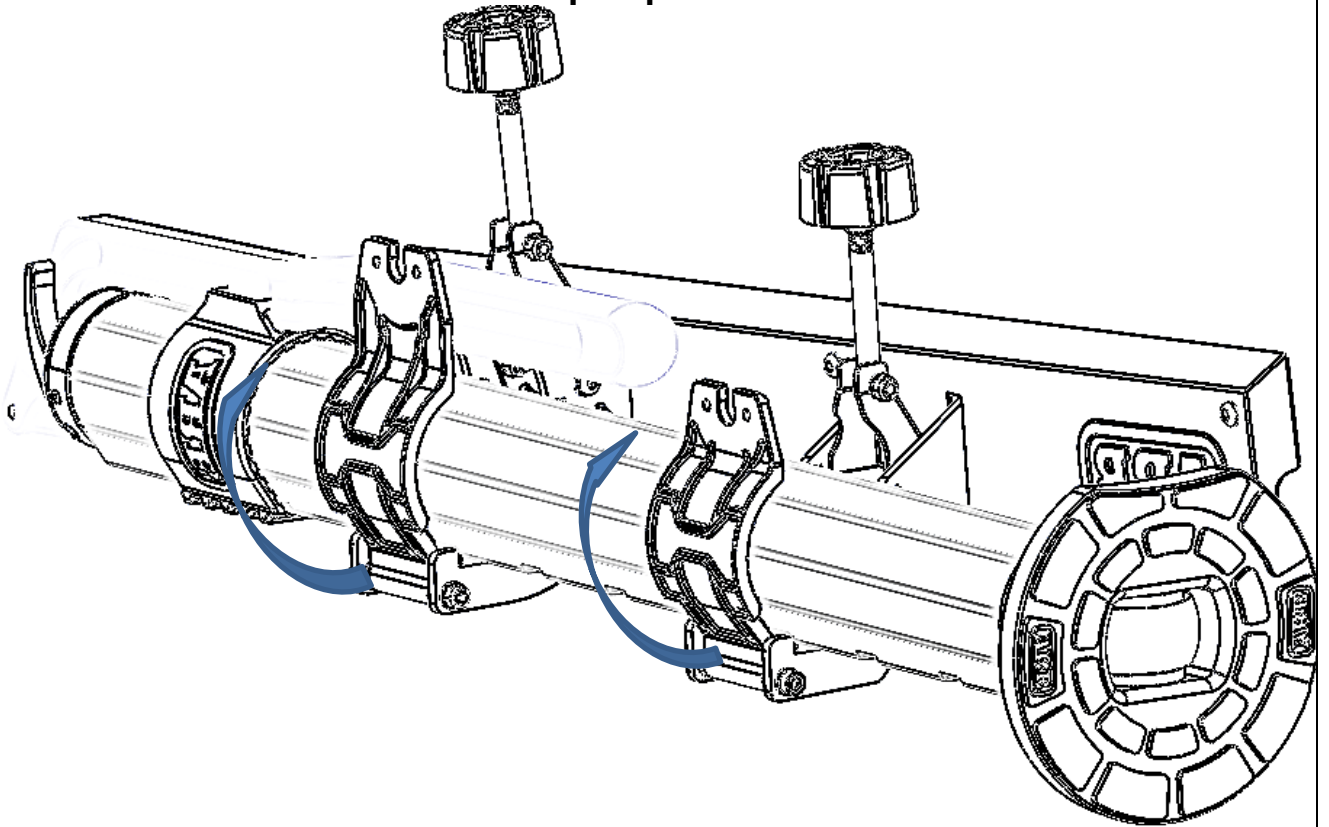

Bring the knobs down to the clamps.

The knob has a brass button that locates inside the slot on the clamps, this MUST be located correctly before tightening the knob.

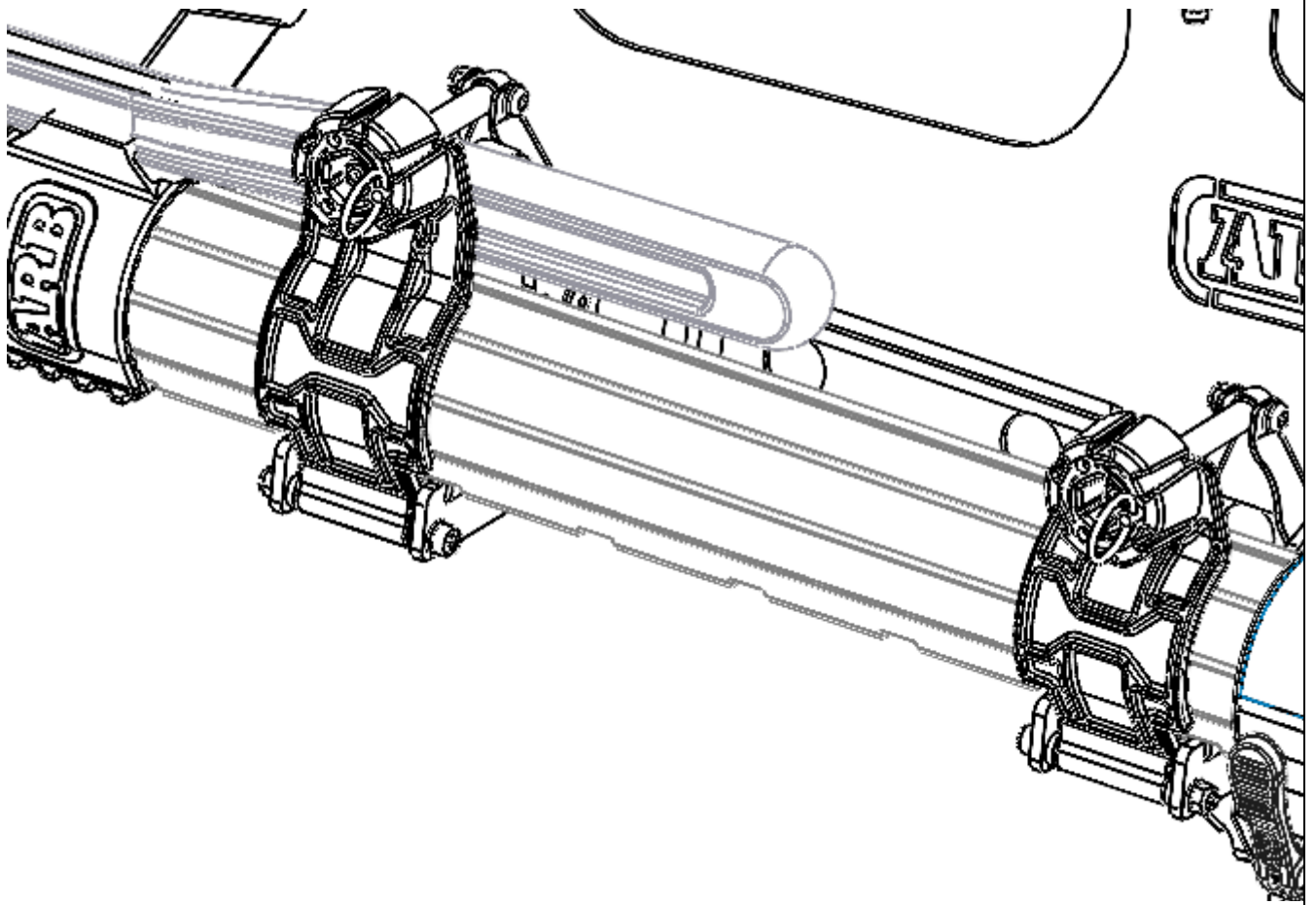

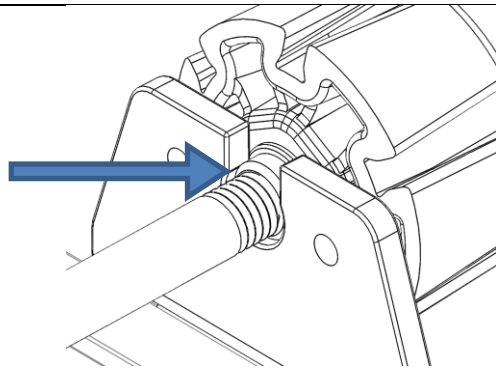

Tighten both knobs a further three and a half turns after initial contact of the knob to the clamp. Align the nearest hole in the knob with either hole on the clamp. Insert the detent pin through the aligned hole on the knob and clamp. Rotate the knob slightly again against the detent pin.

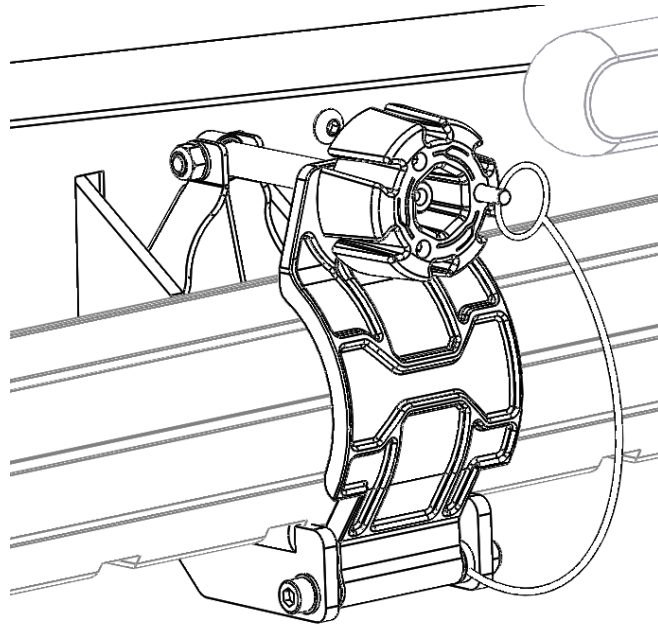

FITTED PRODUCT

