



# FITTING INSTRUCTIONS

Part Number: **2821020 (LH assembly) 2821030 (RH assembly)**

Product Description: RECOVERY POINT

Suited to vehicle/s: TOYOTA LAND PRADO 150 & FJ Cruiser  
(Fitted with OEM bumper or ARB bull bar)

**Please place these instructions in vehicle glove box when complete.**

## **WARNING**

### REGARDING VEHICLES EQUIPPED WITH SRS AIRBAG:

When installed in accordance with these instructions, the vehicle protection panels do not affect operation of the SRS airbag.

### ALSO, NOTE THE FOLLOWING:

- ◆ This product must be installed exactly as per these instructions using only the hardware supplied.
- ◆ Do not use this product for any vehicle make or model, other than those specified by ARB.
- ◆ Do not remove labels (if any) from this product.
- ◆ This product or its fixing must not be modified in any way.
- ◆ The installation of this product may require the use of specialized tools and/or techniques
- ◆ These instructions are correct as at the publication date. ARB Corporation Ltd. cannot be held responsible for the impact of any changes subsequently made by the vehicle manufacturer
- ◆ During installation, it is the duty of the installer to check correct operation/clearances of all components
- ◆ Work safely at all times
- ◆ Unless otherwise instructed, tighten fasteners to specified torque

## **ARB 4x4 ACCESSORIES**

Corporate Head Office

42-44 Garden St  
Kilsyth, Victoria  
AUSTRALIA 3137

Tel: +61 (3) 9761 6622  
Fax: +61 (3) 9761 6807

Australian enquiries  
North & South American enquiries  
Other international enquiries

sales@arb.com.au  
sales@arbusa.com  
exports@arb.com.au

**www.arb.com.au**

# IMPORTANT INFORMATION. GENERAL CARE AND MAINTENANCE

By choosing an ARB Recovery Point, you have bought a product that is one of the most sought after 4WD products in the world. Your recovery point is a properly engineered, reliable, quality accessory that represents excellent value. To keep your recovery point in original condition it is important to care and maintain it following these recommendations:



As part of any Pre Trip Preparation, or on an annual basis, it is recommended that a thorough visual inspection of the recovery point is carried out, making sure that all bolts and other components are torqued to the correct specification. Replace any components as necessary. This service can be performed by your local authorised ARB Stockist.

## FITTING REQUIREMENTS

### REQUIRED TOOLS FOR FITMENT OF PRODUCT:

<b>BASIC TOOL KIT</b>	<b>ANGLE GRINDER AND CUTTING DISC</b>
<b>TORQUE WRENCH 25-96Nm</b>	<b>HAND FILE</b>
<b>SIKAFLEX</b>	<b>JIG SAW</b>
<b>POWER DRILL &amp; 10mm DRILL BIT</b>	<b>AUTOMOTIVE GRADE BLACK SPRAY PAINT</b>

### HAVE AVAILABLE THESE SAFETY ITEMS WHEN FITTING PRODUCT:

<b>Protective eyewear</b>	
<b>Hearing protection</b>	

**NOTE:** 'WARNING' notes in the fitting procedure relate to OHS situations, where to avoid a potentially hazardous situation it is suggested that protective safety gear be worn or a safe work procedure be employed. If these notes and warnings are not heeded, injury may result.

### FASTENER TORQUE SETTINGS:

SIZE	Torque Nm	Torque lbft
M12x1.25	96	71
M12x1.75	87	64
M8x1.25	25	18

<b>PARTS LISTING</b>			
<b>APPLICATION.</b>	<b>PART NO.</b>	<b>QTY.</b>	<b>DESCRIPTION.</b>
FIT RECOVERY POINT	3759450	1	RECOVERY POINT MAIN ASSEMBLY
	3194155	1	PLATE CAGE NUT PRADO
	6151306	1	NUT CAGED M12 1.8-3.2
	6151690	1	BOLT M8 x 1.25 x 90 Gd 10.9 ZP
	6151360	1	BOLT M12 x 1.75 x 35 Gd 8.8 ZP
	6151689	3	BOLT M12 x 1.25 x 90 Gd 10.9 ZP
	6151480	2	NUT HX FL M12 x 1.25 Gd 8.8 ZP 480
	4581303	1	WASHER FLAT M8 x 26 x 2.8 ZP black
	4581049	4	WASHER FLAT ½"
	4721817	1	TUBE CRUSH 12.6 x 17 x 60mm
WING UNDER PANEL CUT-OUT	6191014	1	PINCH WELD 330mm
SAFETY	2125484	1	RECOVERY POINT WARNING LABEL
	211433	1	VEHICLE RECOVERY BOOKLET
	211512	1	OPERATIONS INSTRUCTION CARD

**NOTE: LHS and RHS recovery point assemblies are symmetric. Installation procedure for RHS recovery point (Part No. 2821030) is an exact mirror of LHS recovery point (2821020) unless otherwise specified. All images are of LHS installation unless otherwise specified.**

## FITTING PROCEDURE FOR PRADO 150 (VEHICLE FITTED WITH FACTORY BUMPER)

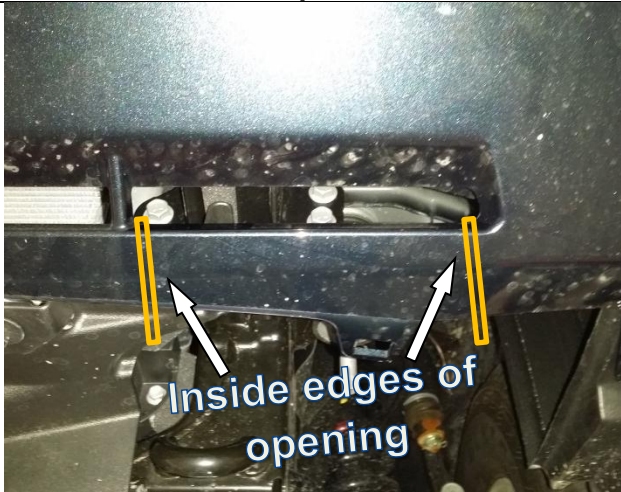

Prado Oct '13 Onwards

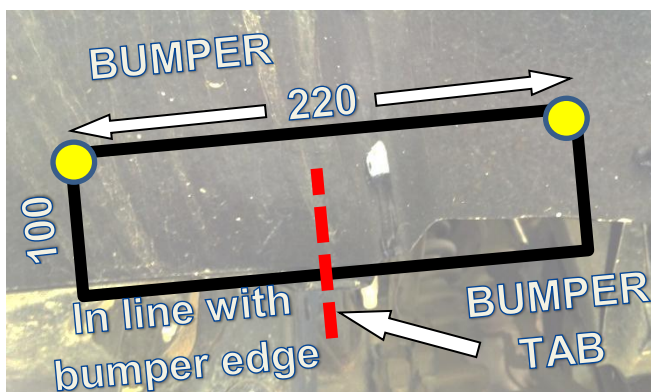

Prado Pre MY13

1. Cut lower section of bumper as shown to allow for clearance to recovery point. Cut is only required for side in which recovery point is to be fitted. Use a jig saw to perform this task. It is advised to drill a hole in each corner for the Pre MY13 model bumper (using a 10mm drill bit) before cutting. This will allow the pinch weld to sit neater on the cut edges.
2. Position pinch weld supplied in kit around cut edges and discard any excess length.

**Place a small amount of Sikaflex on cut edges before applying pinch weld.**

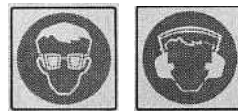

3. Remove radiator top cover by removing the plugs as shown. Retain for re-fitting.



4. Remove the four bolts which retain the top of the grille as shown. Retain for re-fitting.



5. Remove grille by releasing the lower tabs connected to the bumper shown.

VX and Kakadu only: Unplug the camera as the grille is removed.



6. Remove the screws securing the bumper to wheel arch area and across the lower section across the front so that there are no more fasteners securing the bumper.
7. Remove the lower joining panel from the bumper to the sump guard.
8. Work the inner guard liners away from the bumper and reaching in behind, undo the connections to the following if fitted: fog lamps, parking sensors (connection is on LHS of vehicle), headlamp washers (use a cable tie to crimp off the hose to prevent washer bottle leaking).





9. Carefully (ideally with the aid of another person) unclip each outer of the bumper at the guard as shown and remove bumper.



10. Remove impact beam at mounts to chassis by removing M10 bolts. Retain bolts and impact beam for re-fitting.



11. Loosen M12 nut from body mount bolt until it reaches near the edge of bolt thread (do not remove nut or bolt).

Only loosen side that the recovery point is being mounted to.

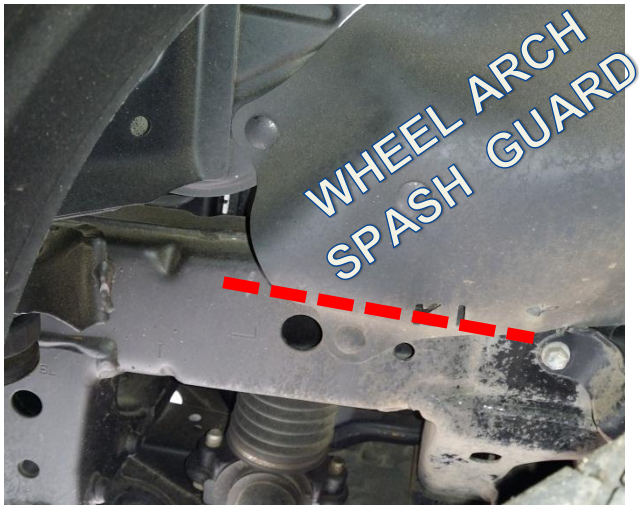

12. On some models the wheel arch splash guard may clip into a lower section of the chassis compared to others. You can check this by holding the recovery point up against the chassis (aligning the mounting holes) and checking if it interferes.

If this is the case, cut section of splash guard retaining clip as shown. Dispose of clip.

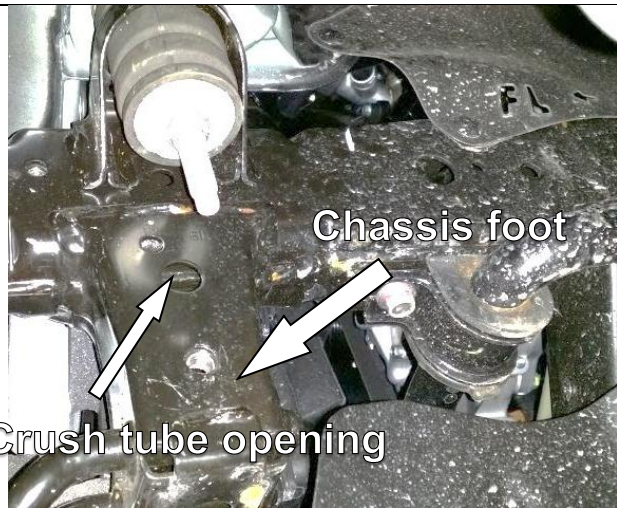

13. Loosely fasten recovery point to chassis using M8 x 1.25 x 90mm bolt, M8 x 26 x 2.8 washer (black), two M12 x 1.25 x 90 bolts, two M12 washers, 60mm crush tube and M12 flange nut.

When requiring access to top M12 bolt for fastening recovery point to chassis, lift the body mount bolt out of the way. Crush tube must be positioned inside chassis foot opening.

**Note: When positioning crush tube in chassis, take care not to let crush tube fall down into chassis foot as it will be very difficult to retrieve.**

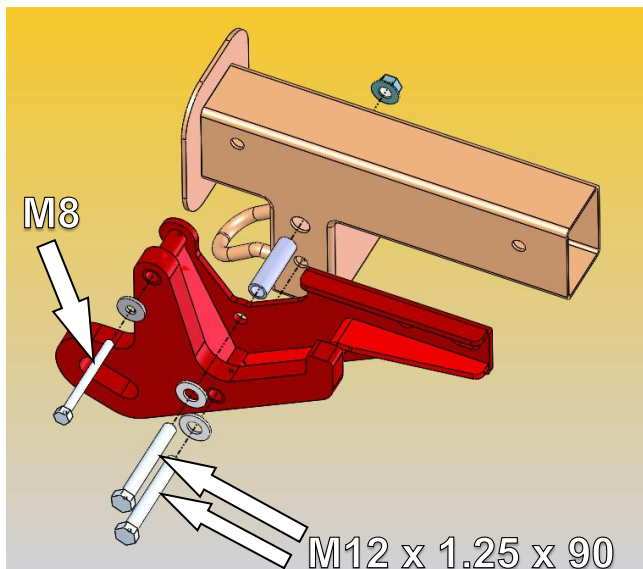



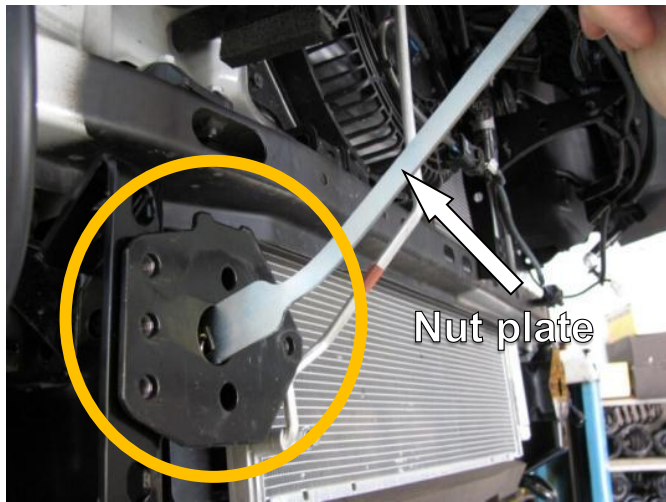

(RHS shown)

14. Insert M12 cage nut into nut plate extension and position nut plate into chassis opening at front.

Note that for recovery point being fitted to RHS, the nut plate extension will need to be bent up as shown. This is to clear the cross tube in the chassis.

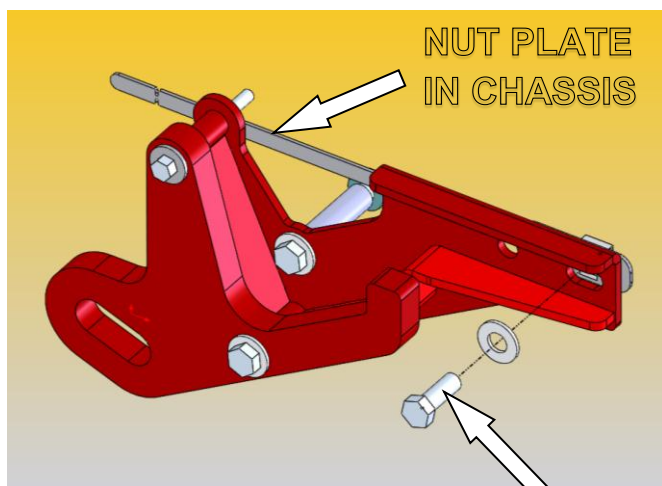

M12 x 1.75 x 35

15. Position M12 x 1.25 x 35mm bolt and M12 washer in rear mounting hole as shown. Tighten to torque specification below.



M12 x 1.75

87Nm



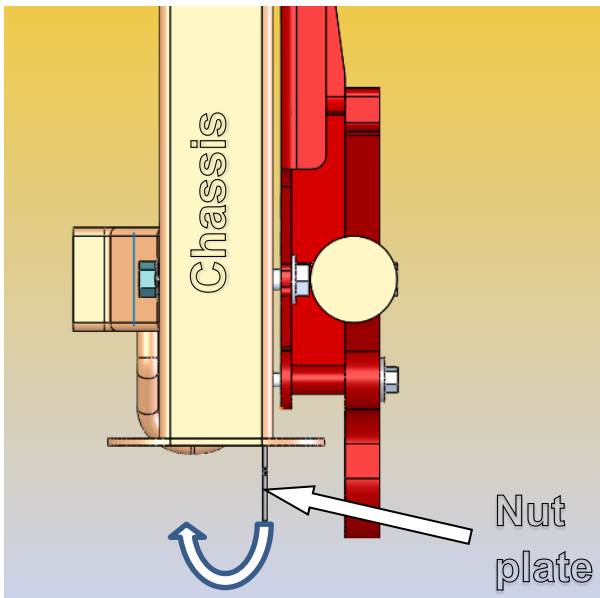

16. Tighten the remaining fasteners joining recovery point to chassis.
17. Re-tighten body mount bolt.
18. Bend nut plate or break off end at notch if necessary so that it does not protrude from opening in the chassis when looking from the top.



M12 x 1.25

**96Nm**



M12 x 1.75

**87Nm**



M8 x 1.25

**25Nm**



M12 body-mount bolt

**74Nm**

19. Re-fit impact absorber and bumper in reverse order to removal.
20. Position warning label on the lower section of the bumper next to the cut-out performed in STEP 1.

## FITTING PROCEDURE FOR FJ CRUISER (VEHICLE FITTED WITH FACTORY BUMPER)



1. Remove protective plate if fitted.



2. Remove plastic cover located under bumper from whichever side the recovery point is to be installed.



3. Remove front fasteners from stone tray. Retain fasteners for reuse.



4. Remove screws in lower bumper and in wheel arch.



5. Remove grille. Screws are located in tabs at the top of the grille.  
Release clips that are located on inside lower section.

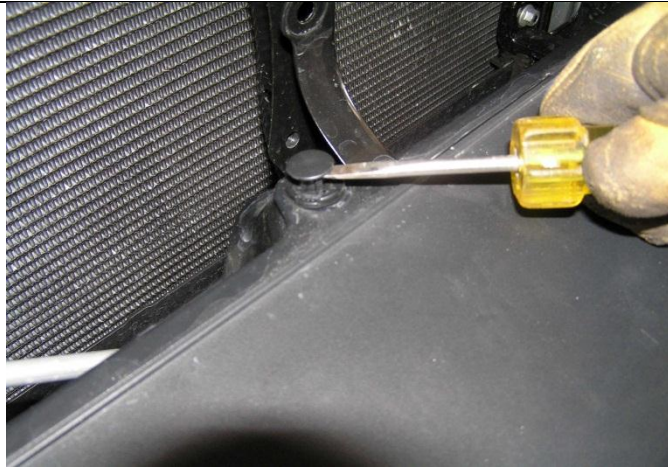

6. Remove plastic rivets along top of bumper.

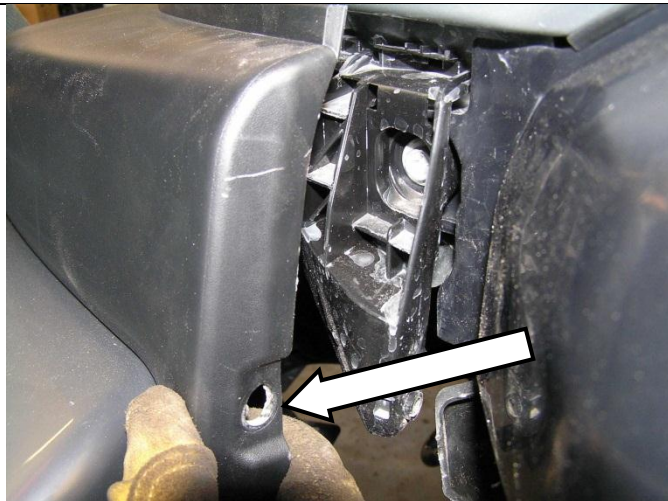

7. Remove screw then remove front bumper cover from vehicle.

*NOTE: Prise the rear lip of the bumper off the retaining spigot where screw was located (as shown with arrow) then pull bar wing outward.*



8. Remove front impact beam (8 flange nuts).  
Retain impact beam and nuts for re-fitting.





9. Fit an M12 cage nut into the nut plate extension.

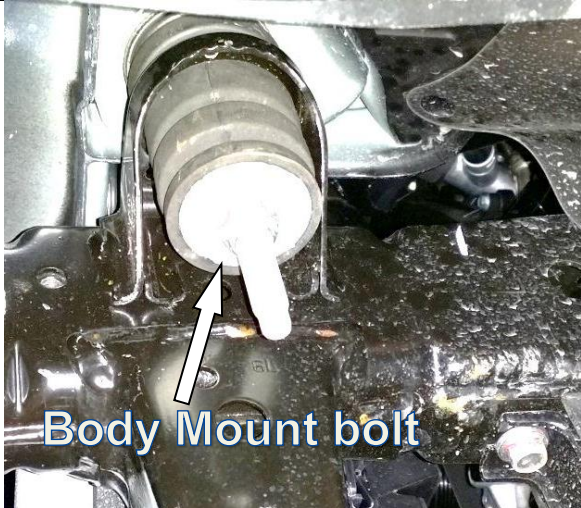

10. Loosen nut from body mount bolt until it reaches near the edge of bolt thread (do not remove bolt).

Only loosen side that the recovery point is being mounted to.



11. On some models the wheel arch splash guard may clip into a lower section of the chassis compared to others. You can check this by holding the recovery point up against the chassis (aligning the mounting holes) and checking if it interferes.

If this is the case, cut section of splash guard retaining clip as shown. Dispose of clip.



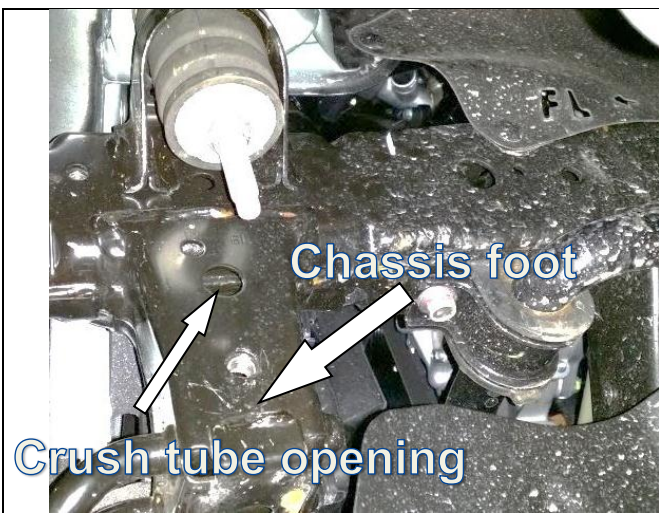

12. Loosely fasten recovery point to chassis using M8 x 1.25 x 90mm bolt, M8 x 26 x 2.8 washer, two M12 x 1.25 x 90 bolts, two M12 washers, 60mm crush tube and M12 flange nut.

When requiring access to top M12 bolt for fastening recovery point to chassis, lift the body mount bolt out of the way. Crush tube must be positioned inside chassis foot opening.

**Note:** When positioning crush tube in chassis, take care not to let crush tube fall down into chassis foot as it will be very difficult to retrieve.

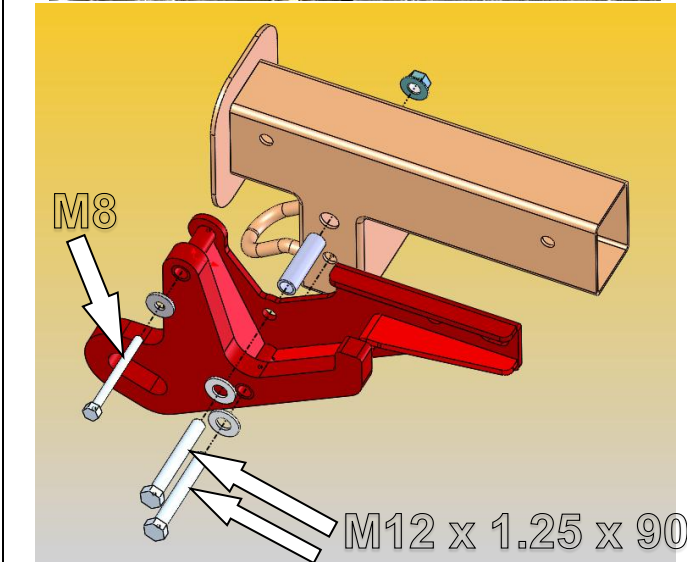

13. Position nut plate into chassis opening at front.

**(RHS shown in image)**



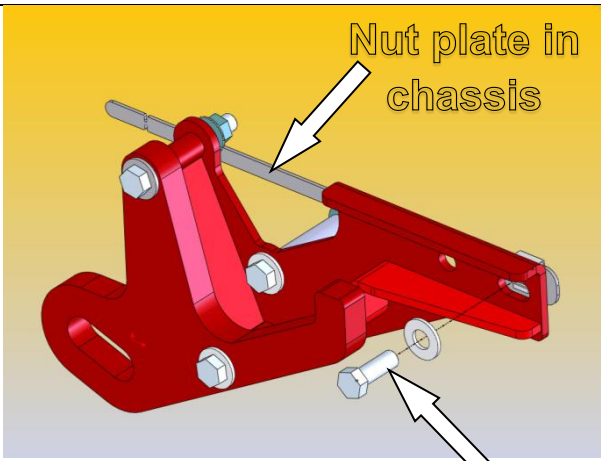

M12 x 1.75 x 35

14. Position M12 x 1.25 x 35mm bolt and M12 washer at rear mounting hole as shown. Tighten.



M12 x 1.75

87Nm

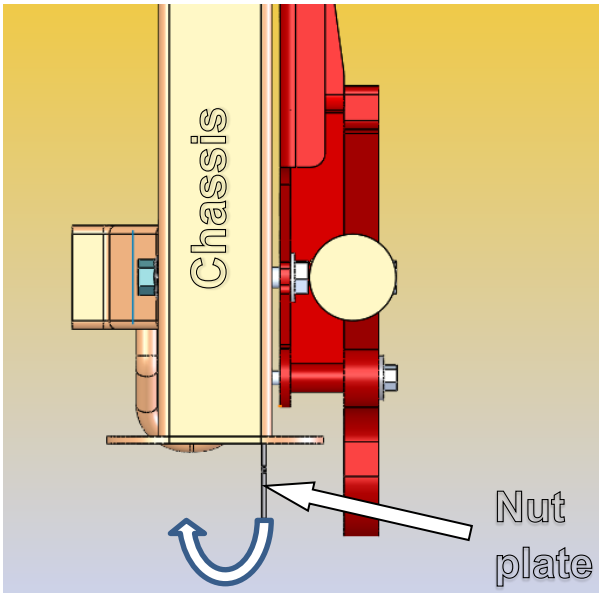

15. Tighten remaining fasteners joining recovery point to chassis.

16. Re-tighten body mount bolt.

17. Bend nut plate or break off end at notch if necessary so that it does not protrude from opening in chassis when looking from the top.



M12 x 1.25

96Nm



M12 x 1.75

87Nm



M8 x 1.25

25Nm



M12 body-mount bolt

74Nm

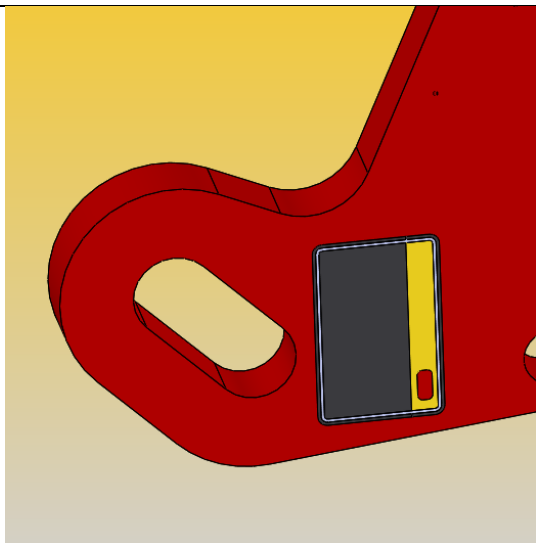

18. Re-fit impact absorber and bumper in reverse order to removal.

19. Position warning label on recovery point as shown.

## FITTING PROCEDURE FOR PRADO 150 (Fitted with an ARB bull bar)



1. Remove ARB bull bar along with ARB impact absorber, chassis mount bracket(s), braces and under-panels.

(Refer to ARB bull bar fitting instructions that came with the bull bar).

*Note: Do not remove chassis mount bracket connected to chassis on the side you are not fitting a recovery point to.*

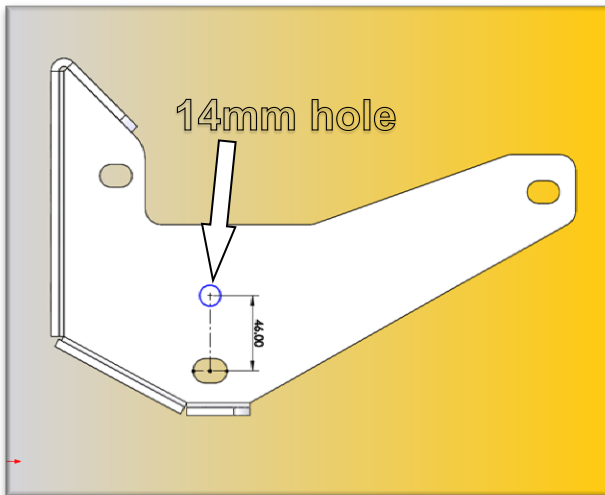

2. Drill a 14mm hole at the position shown marked 46mm directly above existing mounting hole on the chassis mount bracket removed in STEP 1.

Apply black spray paint to cut edges of drilled hole.

*Note: This is only required on the side the recovery point is being mounted to.*

**(RHS drilling procedure is symmetrically opposite).**

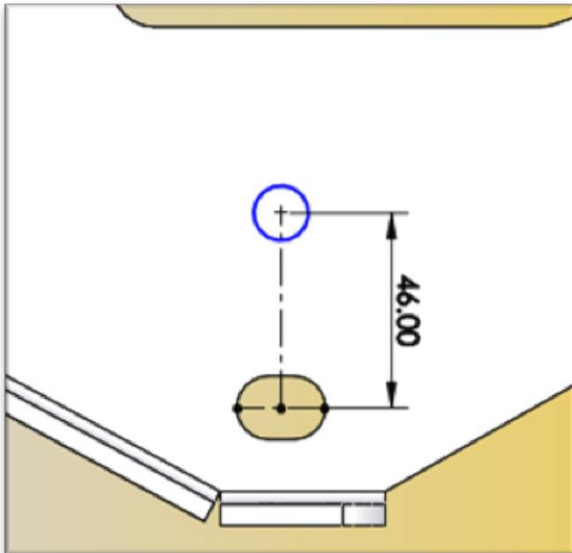



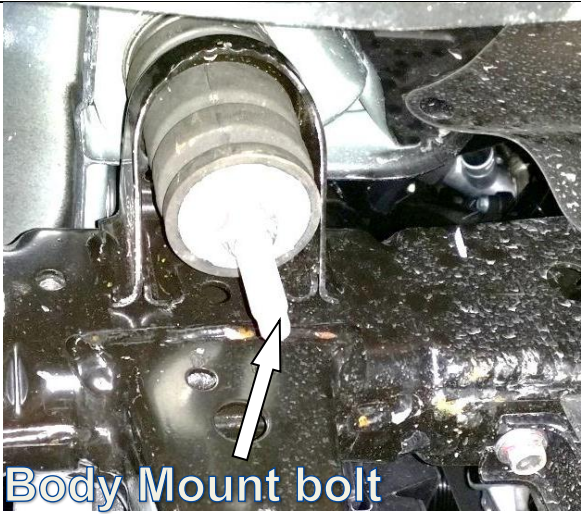

- Loosen nut from body mount bolt until it reaches near the edge of bolt thread (do not remove bolt).

Only loosen side that the recovery point is being mounted to.

Chassis mount  
bracket

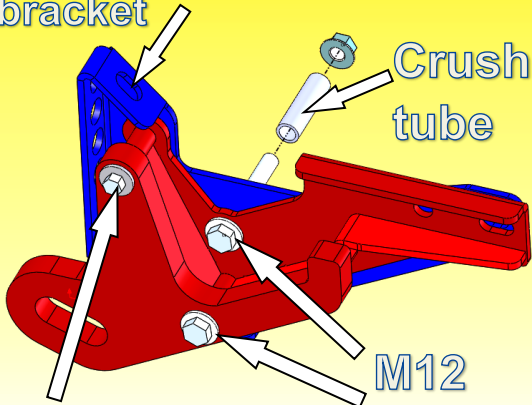

M8 ('13 on)  
M12 (Pre MY13)

- Position recovery point against chassis mount bracket and loosely fasten to chassis using:

**Prado 150 Oct '13 onwards**

2x M12x1.25x90 bolts, 2x M12 washers, 1x crush tube, 1x M12x1.25 flange nut, 1x M8x1.25x90 bolt and M8 washer.

**Prado 150 Pre MY13**

3x M12x1.25x90 bolts, 3x M12 washers, 1x crush tube, and 2x M12x1.25 flange nuts.

When requiring access to top M12 bolt for fastening recovery point to chassis, lift the body mount bolt out of the way.

Crush tube must be positioned inside chassis foot opening.

*Retain flange nuts on a ring spanner to hold them in position.*

**Note: When positioning crush tube in chassis, take care not to let crush tube fall down into chassis foot as it will be very difficult to retrieve.**

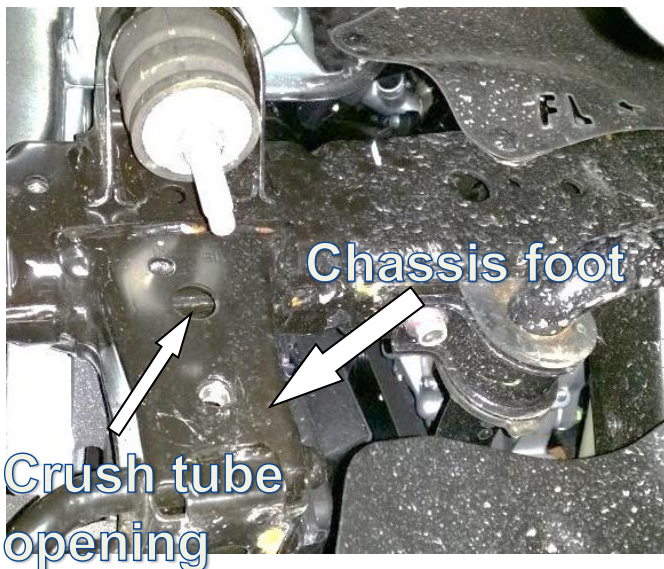



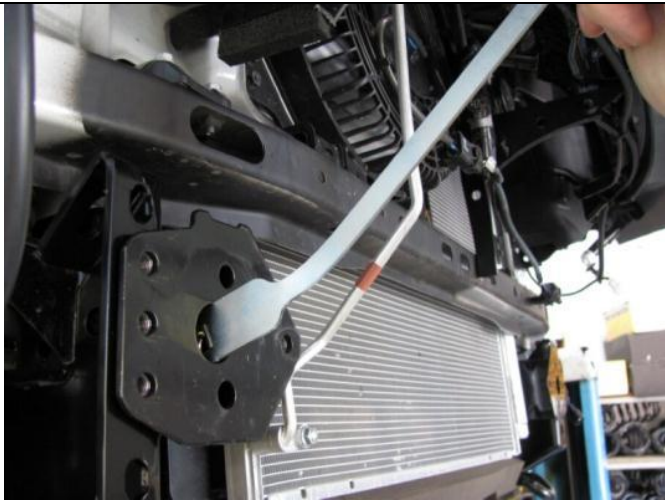

(RHS shown)

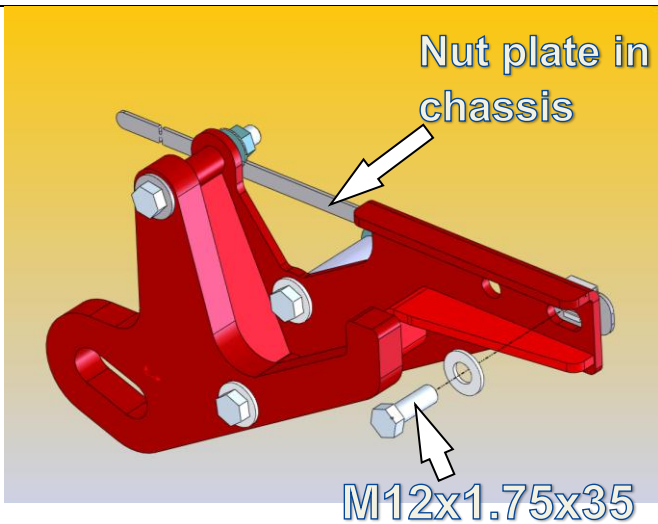

5. Insert M12 cage nut into nut plate extension and position nut plate into chassis opening at front.

Note that for recovery point being fitted to RHS, the nut plate extension will need to be bent up as shown. This is to clear the cross tube in the chassis.

6. Position M12 x 1.25 x 35mm bolt and M12 washer at rear mounting hole as shown. Tighten.



M12 x 1.75

87Nm

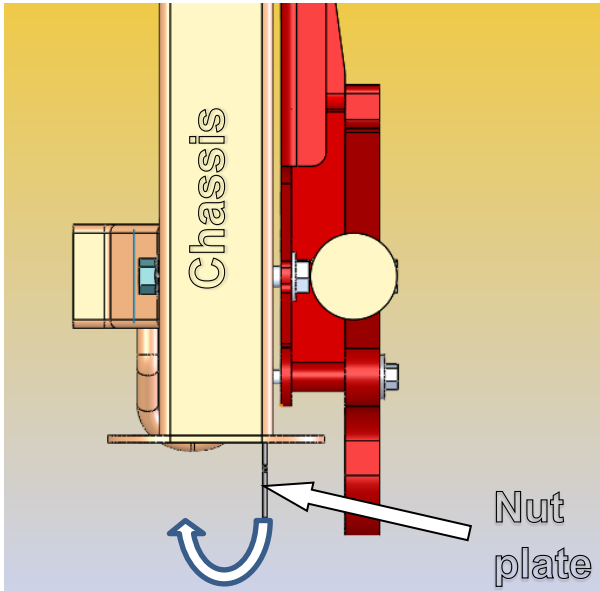

7. Tighten remaining fasteners joining recovery point to chassis.
8. Re-tighten body mount bolt.
9. Bend nut plate or break off end at notch if necessary so that it does not protrude from opening in chassis when looking from the top.



M12 x 1.25

**96Nm**

M12 x 1.75

**87Nm**

M8 x 1.25

**25Nm**

M12 body-mount bolt

**74Nm**

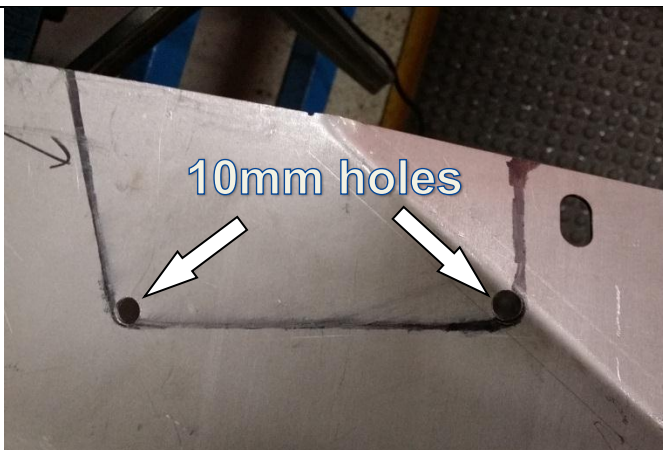

10. Cut-out wing under-panel template located at the end of these instructions which corresponds to the vehicle model the recovery is being fitted to.
11. Stick template onto loose wing under panel using masking tape or similar, on the side which the recovery point is being mounted to.
12. Mark inside edges of the template onto wing under-panel using a black marker and punch centre holes in corners using a hole punch.
13. Drill 2 x 10mm holes in the corners where punched using a drill and 10mm drill bit.
14. Using a jig-saw, cut around marked line of wing under-panel.
15. Clean up cut edges using a hand file.
16. Apply black spray paint to cut edges and let dry.





17. Apply small amount of Stikaflex to cut edges where the pinch weld is to be applied.  
Apply pinch weld and cut off any excess length.

*Note: Cut pinch weld off where it reaches bend.*

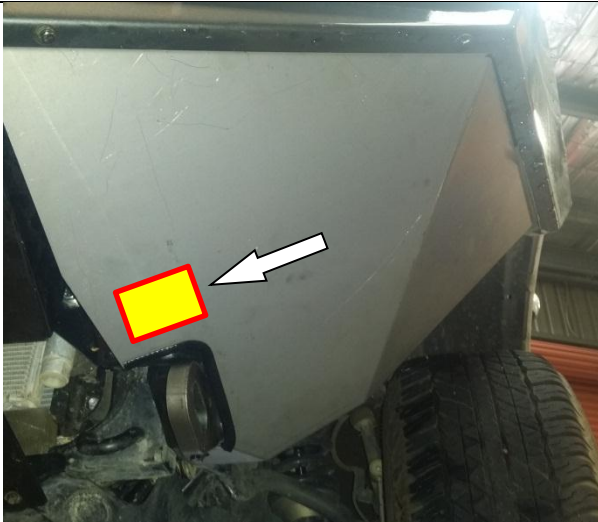

18. Re-fit bull bar and associated components in reverse order to removal.
19. Position warning label on wing under-panel as shown.



## FITTING PROCEDURE FOR FJ CRUISER (Fitted with an ARB bull bar)



1. Remove ARB bull bar along with ARB impact absorber, chassis mount bracket(s), braces and under-panels.

(Refer to ARB bull bar fitting instructions that came with the bull bar).

*Note: Do not remove chassis mount bracket connected to chassis on the side you are not fitting a recovery point to.*

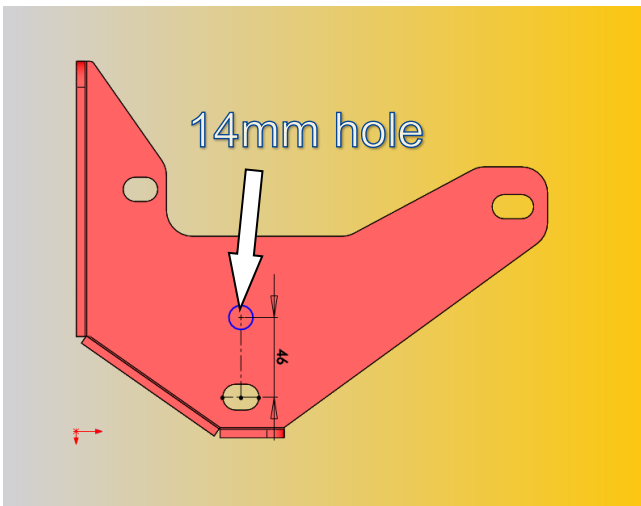

2. Drill a 14mm hole at the position shown marked 46mm directly above existing mounting hole on the chassis mount bracket removed in STEP 1.

Apply black spray paint to cut edges of drilled hole.

*Note: This is only required on the side the recovery point is being mounted to.*

**(RHS drilling procedure is symmetrically opposite).**

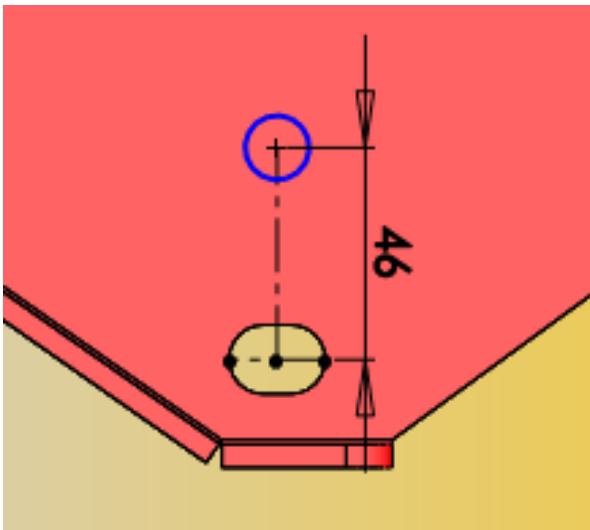



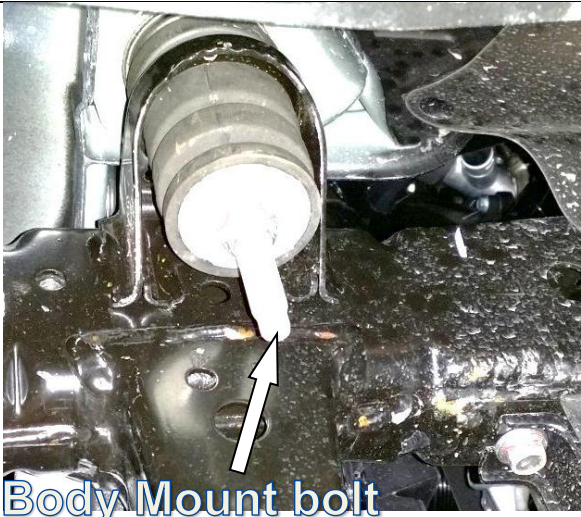

- Loosen nut from body mount bolt until it reaches near the edge of bolt thread (do not remove bolt).

Only loosen side that the recovery point is being mounted to.

Chassis mount bracket

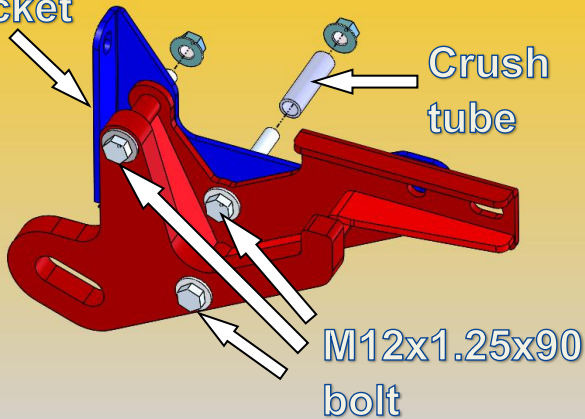

- Position recovery point against chassis mount bracket and loosely fasten to chassis using 3x M12x1.25x90 bolts, 3x M12 washers, 1x crush tube and 2x M12x1.25 flange nuts.

When requiring access to top M12 bolt for fastening recovery point to chassis, lift the body mount bolt out of the way.

Crush tube must be positioned inside chassis foot opening.

*Retain flange nuts on a ring spanner to hold in place.*

**Note: When positioning crush tube in chassis, take care not to let crush tube fall down into chassis foot as it will be very difficult to retrieve.**

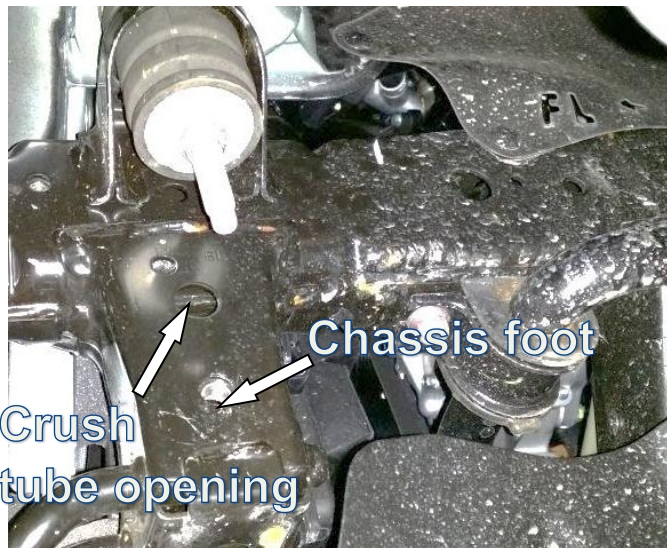



(LHS assembly shown)



(RHS shown)

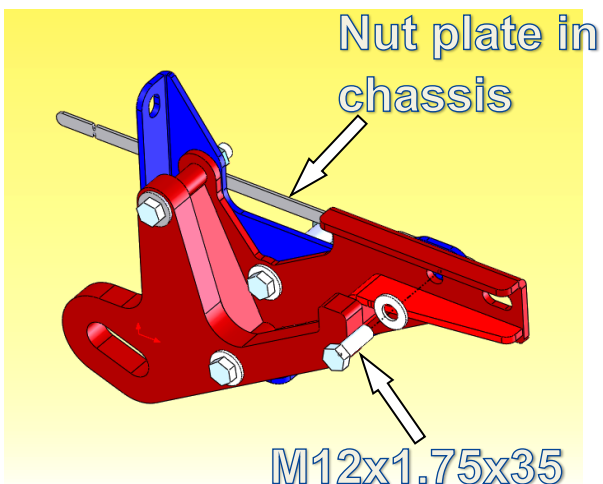

5. Fit M12 cage nut into nut plate and insert nut plate into chassis opening at front.

6. Position M12 x 1.25 x 35mm bolt and M12 washer at rear mounting hole as shown. Tighten.



M12 x 1.75

87Nm

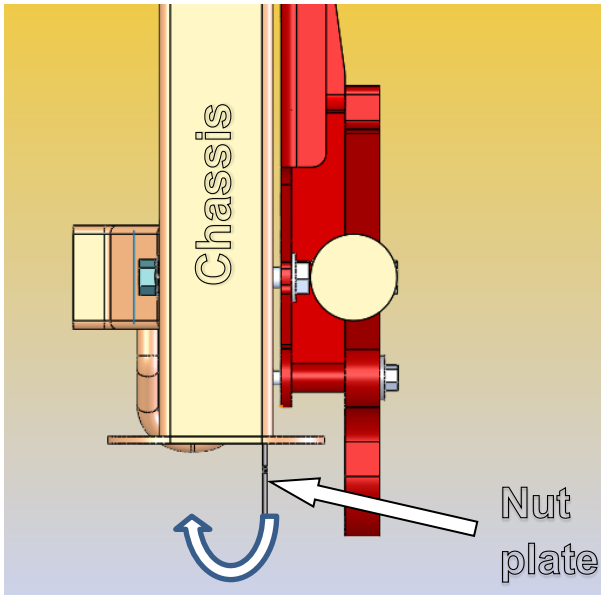

7. Tighten remaining fasteners joining recovery point to chassis.
8. Re-tighten body mount bolt.
9. Bend nut plate or break off end at notch if necessary so that it does not protrude from opening in chassis when looking from the top.



M12 x 1.25

**96Nm**



M12 x 1.75

**87Nm**



M8 x 1.25

**25Nm**



M12 body-mount bolt

**74Nm**



10. Cut-out wing under-panel template located at the end of these instructions which corresponds to the vehicle model the recovery is being fitted to.
11. Stick template onto loose wing under panel using masking tape or similar, on the side which the recovery point is being mounted to.
12. Mark inside edges of the template onto wing under-panel using a black marker and punch centre holes in corners using a hole punch.
13. Using a jig-saw, cut around marked line of wing under-panel.
14. Clean up cut edges using a hand file.
15. Apply black spray paint to cut edges and let dry.



16. Apply small amount of Sikaflex to cut edges where the pinch weld is to be applied. Apply pinch weld and cut off any excess length.

*Note: Cut pinch weld off at corner shown.*

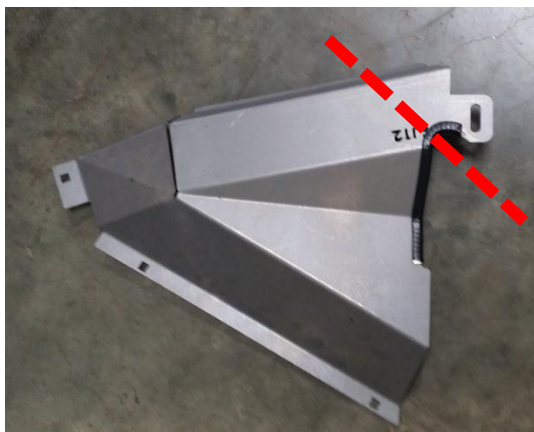





17. Re-fit bull bar and associated components in reverse order to removal.

18. Position warning label on wing under-panel as shown.





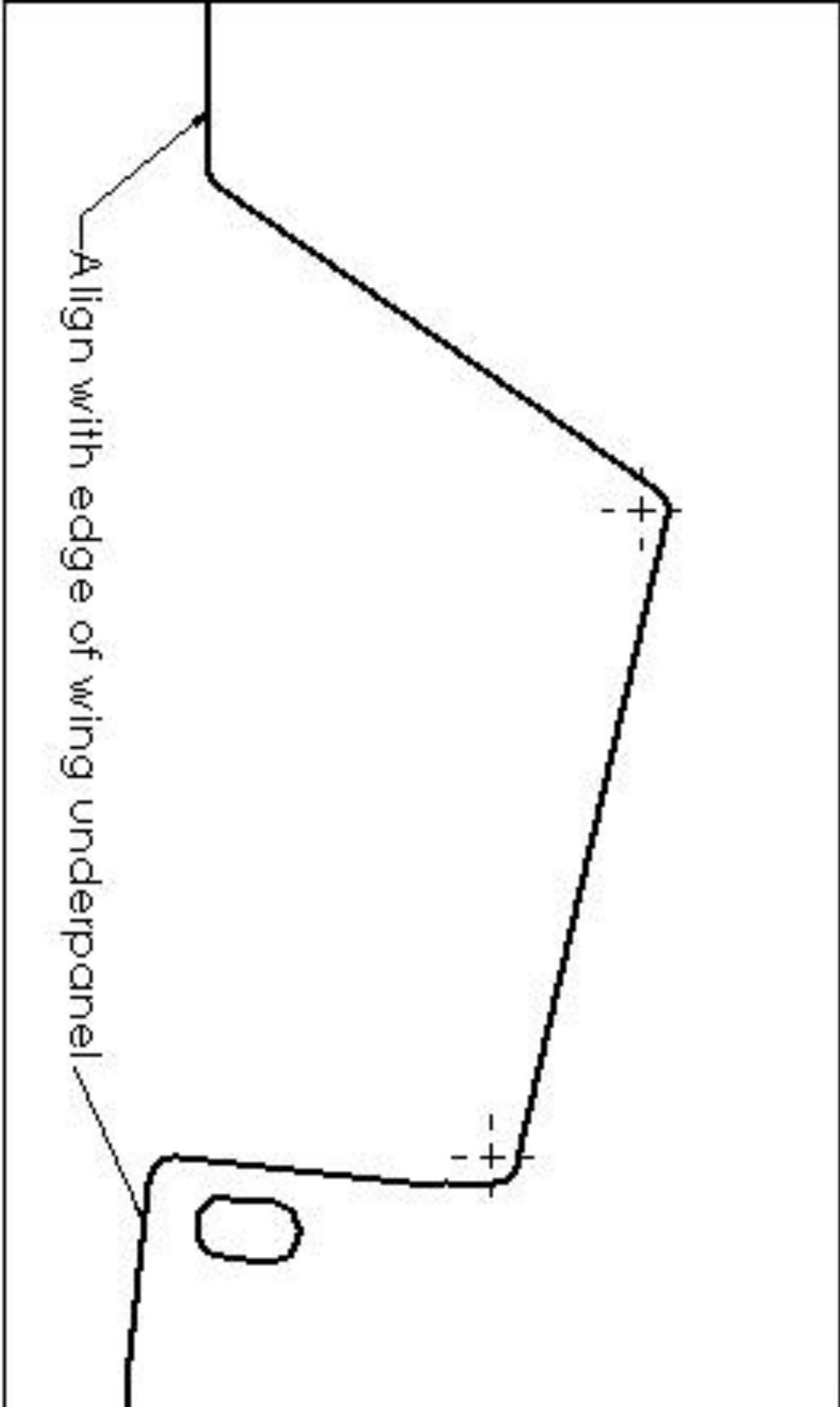

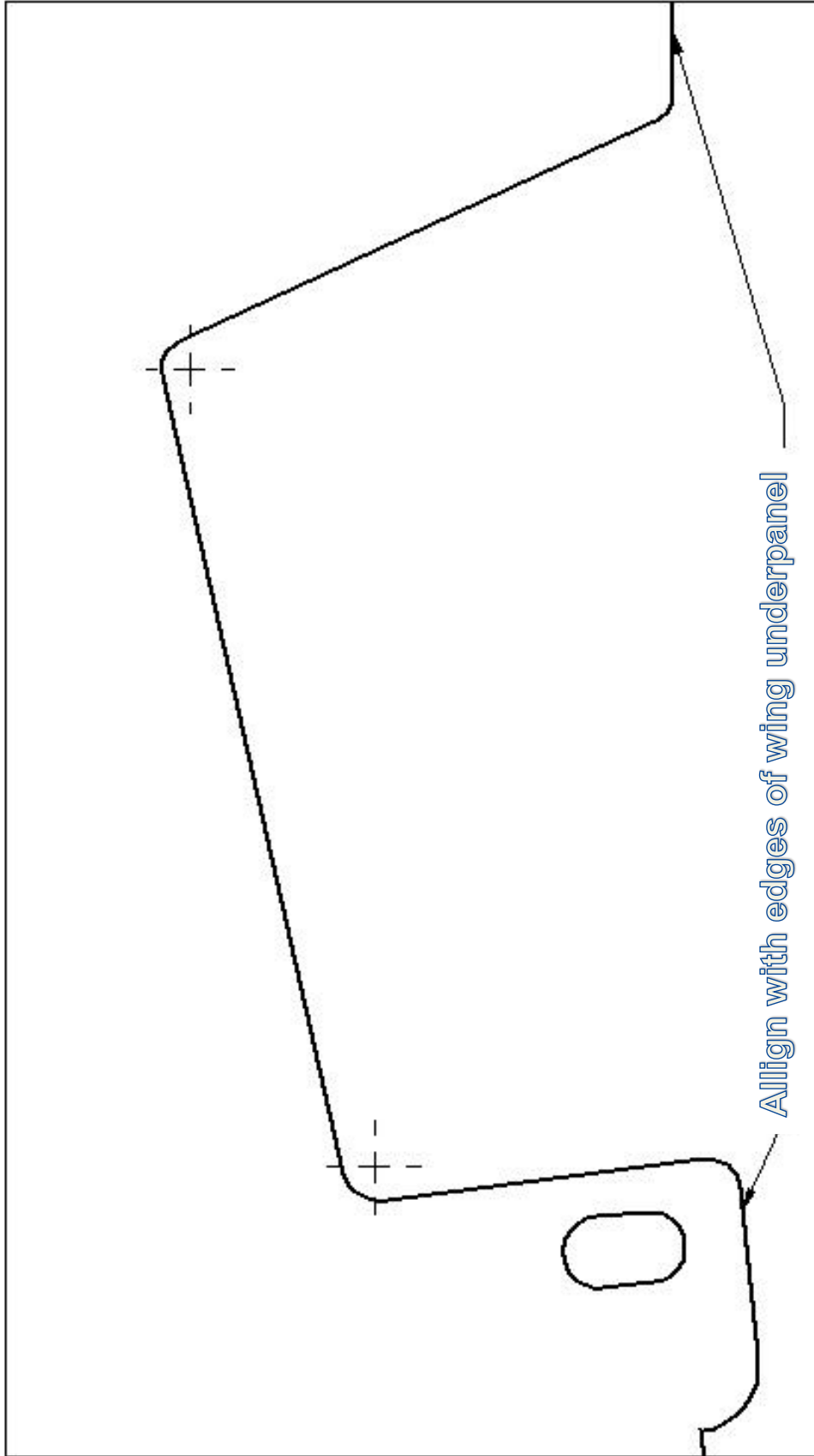

# TEMPLATE WING UNDER-PANEL FJ CRUISER

